

# MOFISTO FILING SYSTEM

The \* MOFISTO \* system provides fast identification, maximum space saving, versatility and potential computer guidance. The dust proof transparent \* ZIP-BAG \* with a glide rib insures safe storage, better and faster availability for inprocess handling, allows better organization and provides the perfect protection against pollution and damage. The ideal solution for the storage of small and large size film, SMD-screens, drawings, pictures and many other items.

Highly accurate film, masks, patterns and other sensitive large items need reliable protection during handling and storage. For this purpose the MOFISTO storage has been developed with the ZIP-BAG.

The zipper sealable, transparent ZIP-BAG is rugged, easy to transport and each SYSTEM-SHELF (tier) offers 100 storage positions, allowing a maximum of storage capacity with a footprint of only 600 mm (24") x 1000 mm (39"). The SYSTEM-SHELF has 100 plastic glide tracks with a length of 600 mm (24"), for a reliable support during removal and insertion of the ZIP-BAG.

The search for a certain ZIP-BAG is easy. Each bag protrudes 50 mm (2") or more from the SYSTEM-SHELF. Labels can be read from the front, without the need of pulling the ZIP-BAG forward from the SYSTEM-SHELF. In addition to the labels mounted on each ZIP-BAG, there is a label mounting surface of 28 mm (1") high at the front of each SYSTEM-SHELF.

Sliding adjacent bags to the right or left, to make room for removal or replacing a bag, as is necessary for other systems is not required.

With a simple tug at the front edge, a selected ZIP-BAG will easily glide from it's stored position into the collector's hand.

The dedicated space of the removed ZIP-BAG remains available for re-insertion after use.

Top tiers can be accessed just as easily. When inserting the ZIP-BAG, the support glide rib must be placed in front of the selected track slot and with a slight push the ZIP-BAG will glide back into its storage position.



## THE SYSTEM-SHELF with \* ZIP-BAG \* .

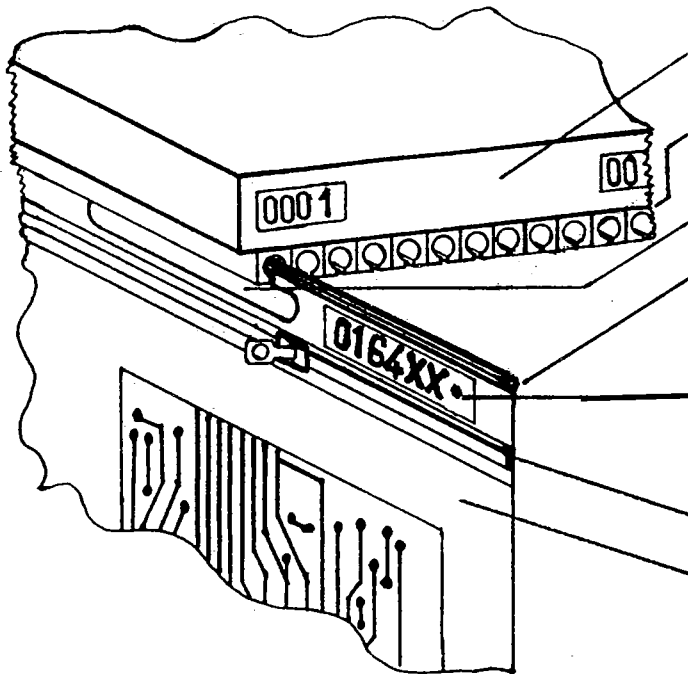

Position for reference labels on the SYSTEM-SHELF, 28 mm (1") high.

TRACK-BLOCKS with 100 tracks.

Carrying handle for easy handling of the ZIP-BAG.

Support glide rib for smooth insertion into TRACK-BLOCK slots.

Identification area, easily visible due to the protruding length of the ZIP-BAG. Readable from front by sliding finger tips across front edges.

Zipper to close the \* ZIP-BAG \* for protection of contents.

\* ZIP-BAG \* is made of transparent material to facilitate recognition of contents.

### The \* ZIP-BAG \* for protected storage.

The complete closed ZIP-BAG provides an optimum protection against dust, fluids, scratching, tearing, nicking, curling and spilling of contents during transport and storage. With the plastic bag material, there is no danger of paper or cardboard particles being transferred from the bag to the stored film. The zipper opens and closes very smoothly. The carrying handle simplifies handling during loading and transportation - this also applies to large size film.

### QUESTIONS AND ANSWERS ABOUT THE \* ZIP-BAG \* !

#### Is the \* ZIP-BAG \* safe for long time storage ?

The plastic material used, has been selected based on recommendations from the photographic industry and is considered ideal for the long time storage of photographic film materials. Other materials may cause harm. We have supplied this type of ZIP-BAG for more than 10 years, without any damage incidents.

#### Is the \* ZIP-BAG \* environment friendly ?

The \* ZIP-BAG \* is made out of a specially formulated PE, which can be recycled with other plastics.

#### What additional protection does the \* ZIP-BAG \* offer ?

Against fire "side effects" such as: water (sprinkler system), smoke and others. This has been proven already during actual fires. Should a bag catch fire, no harmful (acid) smoke is produced, as is the case with PVC bags.

#### Is it possible to store other items with the film material ?

We recommend using an additional bag for storing hard items such as: cassettes, panel samples, etc. to avoid scratching of the stored film. We also offer a bag (without a zipper and at lower cost) for this particular situation.

#### How do I select the proper size \* ZIP-BAG \* ?

1. The useable bag opening is about 20 mm less than the published width of the bag. The tolerance of the width is +/- 5 mm and of the height +/- 10 mm. A \* ZIP-BAG \* size 650 x 450/500 mm (25" x 17"/19") will accept artwork with a maximum size of 625 x 440 mm (24" x 17").

2. The bag length will determine the number of SYSTEM-SHELVES (tiers) that can be installed.

3. All latest information regarding standard sizes can be found in the price list.

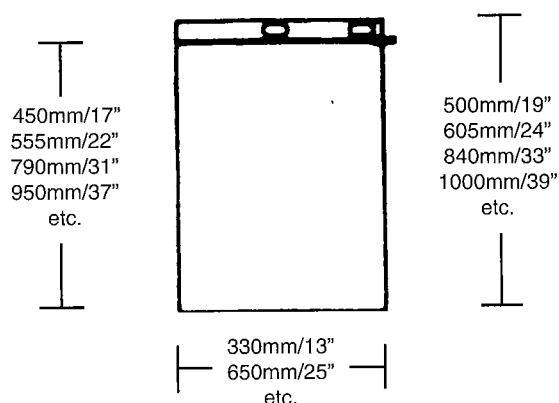

## The \* MOFISTO \* modular shelf system.

Two frames, two tie bars and one or more SYSTEM-SHELVES are necessary for constructing a base storage system. The SYSTEM-SHELF is 1000 mm (40") wide and has 100 tracks for storing 100 ZIP-BAGs. For the first 1000 mm base frame two upright frames are required, for each additional 1000 mm wide frame only one upright frame is needed. The SYSTEM-SHELF is positioned with a simple set of 4 pins in holes placed at 50 mm intervals in the frame uprights. The system height usage for different bag length can thus be optimized. Standard frames are available in length of 2000 mm (79"), 2500 mm (98") and 3000 mm (118") and in different colors.

### QUESTIONS AND ANSWER ABOUT THE \* MOFISTO \* SHELF SYSTEM !

#### What is the storage capacity per 1000 mm (40") base width ?

This depends on the selected frame height and distance between SYSTEM-SHELVES. The distance between shelves equals the overall length of the ZIP-BAG plus 40 mm (1,6") for the SYSTEM-SHELF. Storage capacity examples:

Frame height	2000 mm	2500 mm	3000 mm
ZIP-BAG height	capacity	capacity	capacity
500 mm	300 bags	400 bags	500 bags
605 mm	300 bags	300 bags	400 bags
840 mm	200 bags	200 bags	300 bags

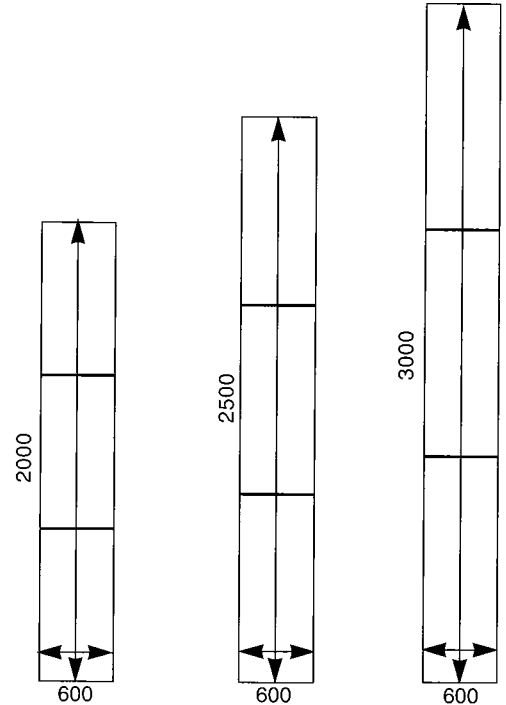
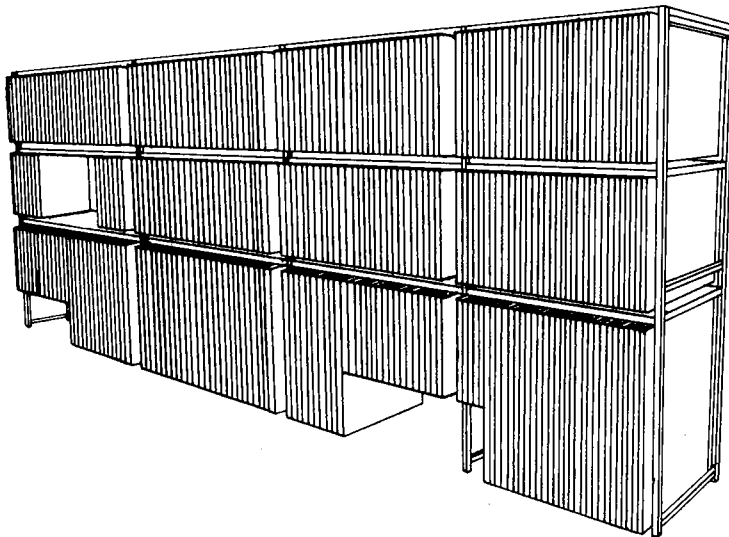

#### Necessary footprint for the shelf system ?

Footprint for a base frame is 1030 mm x 600 mm (40" x 24") and with each additional frame unit there is an increase of 1000mm (39"). The frame depth of 600 mm (24") will increase to 650 mm (26") as a result of the ZIP-BAG width being 50 mm (2") wider and more for even wider ZIP-BAG sizes.

#### Combining the \* MOFISTO \* system with other existing hardware, such as cabinets or other shelving ?

The SYSTEM TRACKS used in a SYSTEM-SHELF can also be supplied as individual TRACK-BLOCKS with 10 tracks. These blocks are supplied with pre-drilled mounting holes and wood screws for fastening.

#### Maximum weight a SYSTEM-SHELF can handle ?

The standard SYSTEM-SHELF has been tested for weights up to 180 kg (400 lbs). To date, this has been found sufficient. If additional weight becomes a requirement, we can easily accommodate.

#### What must be considered when selecting the frame height ?

The system as high as 2000 mm (79") can be used without the aid of a ladder. Top tiers of taller frames need to be accessed with a ladder. If the full height of a frame is not be required (adding ZIP-BAG heights of necessary tiers together), the top tier can be mounted at a lower position than the top of the frame itself to accommodate better access.

## The \* MOFISTO \* T-KADDY.

A T-KADDY has 4 swivel wheels, of which 2 can be locked in a rigid position. Each T-KADDY is supplied with the SYSTEM-SHELF. The maximum load is 200kg (400 lbs.) and the footprint is 1030 mm x 600 mm (40" x 24") plus the additional ZIP-BAG width. Available heights are 1200mm (47") or 1800mm (70").

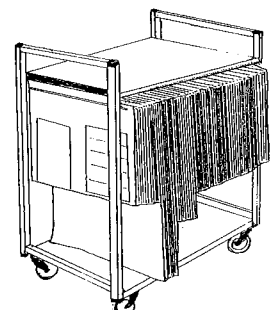

## The \* MOFISTO \* T-KADDY.



The mobile T-KADDY is an ideal addition to a stationary shelf system or an ideal solution for limited storage needs. Transportation of film etc. from the storage area to the work place is greatly simplified and the ZIP-BAG can be accessed anywhere.

### Ideal storage applications using \* MOFISTO \* !

- Electronic:** Film, production samples, spare PC-boards, control tools, test adapters, components.
- Construction:** Drawings, renderings, pictures, disks/CD-ROM, photos, etc.
- Print + Repro:** Photos, film, scripts, disks/CD-ROM, drawings etc.
- Sales:** Datasheets, leaflets, instructions etc.
- Administration:** City/road maps, files, pictures, drawings, instructions.
- Hospital:** Patient profiles, X-ray film, emergency plans, etc.



Patents have been issued in many countries !  
Changes and technical modifications may be implemented without prior notice !